

#### AUTOMATIC BURNER

The automatic burner with patented BEV Technology® is the most advanced product in the industry, ensuring the cleanest burning process without any smoke, smell or ash. The flame is produced by combusting ethanol vapors and has no direct contact with the liquid fuel.

#### FLAME CONTROL

Have control over the fire and take advantage of the 6-stage flame height regulation.

#### GLASS BARRIER

The dedicated tempered glass panel covers and stabilizes the flame.

#### BEST BUILD QUALITY

NetZero burners have passed extensive tests carried out by the leading certification institutes. They're manufactured according to UL standards and are O-TL certified – meeting the most demanding safety and quality requirements.

#### INTEGRATED CONTROL PANEL

This NetZero burner has an intuitive control panel with an LCD screen and inlet for automatic refilling.

#### AUTOMATIC REFILLING SYSTEM

The automatic pump communicates with the device, delivering the necessary amount of fuel. There is no risk of overfilling the tank or spillage.

#### CONTROL OPTIONS

Control the fire with the included remote, app on your smartphone or home automation system.



INCLUDED



INCLUDED



OPTIONAL

**AVAILABLE OPTIONS** Choose one of these packages to add design features that enhance and customize the NetZero Fire experience.

*Ultimate LED and Premium LED Glass Barrier packages are available only with a NetZero firebox.*



#### ULTIMATE LED

Go for maximum visual impact by adding both an LED-lit glass barrier and LED media floor plate to your fire feature.

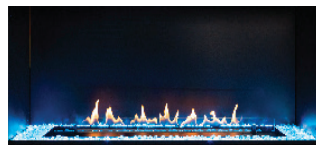

#### PREMIUM LED FLOOR

Upgrade your fire feature with an array of beautiful LED lights that illuminate the media and complement your flames.



#### PREMIUM LED GLASS BARRIER

Surround your burner with a transparent glass barrier enhanced with full-spectrum LED lighting to create a sophisticated and dynamic look.



#### CLASSIC FLOOR

Create a look that's truly yours by adding decorative media such as glass, rocks and marbles.

### Burner Specifications

Fuel Tank Capacity	12.1 gallons
Burn Time	11 - 31.5 hours
Heat Output	32,000 - 94,000 BTU
Fuel Type	Bioethanol 86 - 96.6%
Weight	200 lbs
Minimum Room Cubature	18,800 ft <sup>3</sup>
Flue	Not required
Air Change Rate	1 space per volume per hour
Electrical Connection	115V, 60HZ, min. 20A dedicated breaker
Finish	Black powder coating
Application	For indoor use only
Flame Height Regulation	6 stages

### Clearance & Cavity Measurements - Site-Built Enclosures

A (in)	B (in)	C (in)	D (in)	E (in)	F (in)	G (in)	H (in)
10-1/4"	16"	97-1/4"	108"	2"	14"	20"	40"

### Burner Dimensions

A (in)	B (in)	C (in)	D (in)	E (in)	F (in)
95"	90-5/8"	98"	11"	12"	14-1/8"

### Media Tray Dimensions

A (in)	B (in)	C (in)	D (in)
10-5/16"	15-7/8"	97-1/2"	107-7/8"

For installation specifications and required clearances to combustibles materials, refer to the installation manual.

### Clearances & Cavity - Site-Built Enclosures

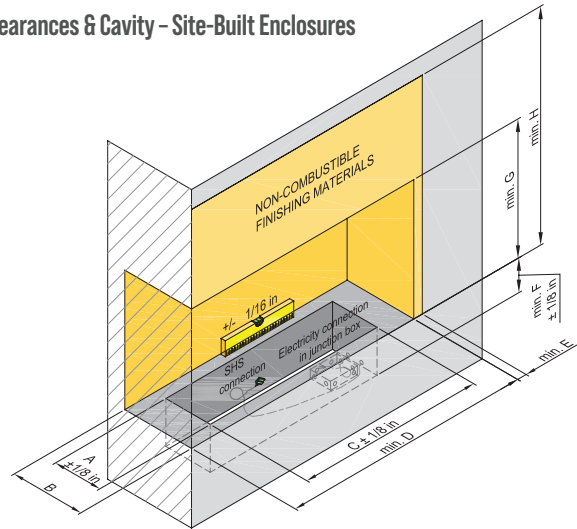

### Burner

### Front View

### Side View

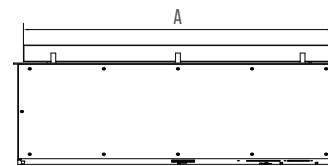

### Top View

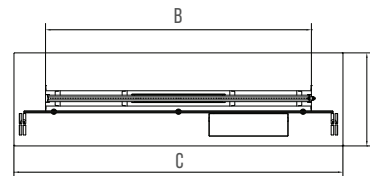

### Media Tray

Burner drops into the Media Tray. Tray dimensions are similar to the cavity measurements.

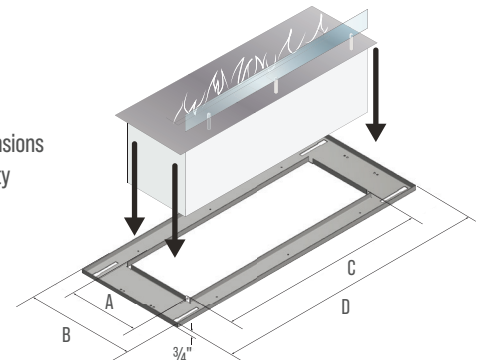

### CUSTOM LENGTHS ARE AVAILABLE



Don't be afraid to go beyond standard designs. We can create a NetZero burner and fire line in any length to meet the expectations of individual clients. Lead time varies depending on length and complexity.

Manufactured to UL Standards | O-TL Certified



NetZero is a distributor of these products, which are designed and manufactured by Planika SP S O O. THERE ARE NO WARRANTIES WHICH EXTEND BEYOND THE DESCRIPTION ON THE FACE HEREOF AND SUPPLIED MANUALS. IMPLIED WARRANTIES OF MERCHANTABILITY, IMPLIED WARRANTIES OF FITNESS, IMPLIED WARRANTIES OF WORKMANSHIP AND OTHER IMPLIED WARRANTIES ARE EXCLUDED BY NETZERO.